



Study of Mobile data management and Optimization Techniques

Ms Jyoti, Ms. Yogita

Assistant Professor Computer Science

Pt. NRS Govt College Rohtak

Abstract

Mobile data management is a complex field that ensures data efficiency on mobile devices and networks. Data synchronisation between devices and servers ensures platform consistency. Caching and prefetching improve mobile device performance by storing frequently used data. In low-connectivity areas, data compression improves bandwidth use and lowers data transmission costs. Context-aware data management considers location, time, and user behaviour to give relevant info. Encryption and access control safeguard user data. Offline data access lets mobile applications work offline and sync with servers when connected. Mobile data analytics uses massive amounts of user data to improve user experience and inform choices. Data backup and recovery guarantee data recovery after loss or device failure. Data de-duplication optimises storage and retrieval. Data governance enforces legislation and industry standards for data access, use, and retention. Mobile data management ensures efficient, safe, and reliable data services on mobile platforms while optimising resource consumption and user experience. It underpins current mobile apps and services.

keywords: Mobile data management, Data synchronization, Caching, Prefetching, Data compression

Introduction

The topic of mobile data management is rapidly developing to meet the ever-increasing demands of mobile devices and networks. Due to the widespread use of mobile devices and the rising importance of mobile apps, effective data management is now crucial for delivering satisfying user experiences. Data synchronisation, caching, and prefetching are nebulous notions that maintain data consistency and accessibility even in the absence of a constant internet connection. In order to optimise bandwidth use and lessen the effect of data expenses, data compression is a crucial strategy in mobile data management. By considering the user's location and previous actions, context-aware data management may present data in a way that is more relevant and useful to each individual. Data privacy and security have become more important as the mobile world expands. Users should not worry about their data being compromised thanks to the usage of strong encryption, access limits, and data anonymization methods. In addition, having apps that can still work without an internet connection is a huge plus for user experience. Data-driven choices and enhanced app performance are made possible by mobile data analytics, which gives organisations and developers access to massive amounts of user-generated data. De-duplication improves storage efficiency, while backup and recovery systems safeguard against data loss, especially in data-rich contexts. Mobile data management relies heavily on data governance, which lays the groundwork for ethical data management, regulatory compliance, and industry best practises. In our fast-paced, data-driven world, mobile data management plays a critical role in building the mobile ecosystem, guaranteeing efficient resource use, and improving user experiences. The widespread use of mobile devices like smartphones and tablets has made mobile data management a crucial component of the contemporary mobile experience. Data management on various devices and via mobile networks is a dynamic and challenging undertaking in this quickly changing environment. The theoretical frameworks of mobile data management are in the front of directly confronting these difficulties.



source : Mobile device management

https://cdn.ttgtmedia.com/rms/onlineImages/mobile_computing-mdm_mobile.jpg

One of the most important aspects of mobile data management is keeping all of your data in sync across all of your devices and any cloud services you use. This method ensures that consumers can always get to their information from any device, whether it a mobile phone, tablet, or desktop computer. In addition, it facilitates teamwork settings in which information may be smoothly shared and updated in real time. By proactively saving frequently visited data on the device, caching and prefetching boost the speed of mobile applications. Prefetching helps consumers save time and lessen their dependency on mobile networks by getting data they are likely to require before they actually need it. This results in a more fluid and responsive application experience for the end user. Since more and more people are relying on their mobile devices to access the internet, data compression has become more important. Data compression reduces the quantity of information sent across a network and hence lowers the associated expenses and stresses on the underlying infrastructure. This is particularly helpful in places where access to the internet is costly or sluggish. The state-of-the-art notion of context-aware data management adapts data delivery to each user's unique environment. The place they are right now, the time of day, and their prior habits may all play a role. Mobile apps that take into account the user's location and other contextual factors are better able to meet the individual's demands and provide a more satisfying experience. One cannot stress the significance of data privacy and security in mobile data management. Robust security measures are required because mobile devices store a great deal of sensitive information. This information includes personal data, financial details, and private messages. This information is protected using encryption, access limits, and anonymization to keep users secure from harm and confident in mobile services.

In situations when connection to the internet is few or inconsistent, the option to access data while disconnected from the web is a crucial perk. Mobile app users may still access certain functionality while they aren't connected to the internet thanks to offline support. Users will be more satisfied and loyal if they are able to continue working and having fun without interruption. Businesses may learn a lot about their customers' habits, likes, and dislikes by using mobile data analytics, which is powered by the massive volumes of data created by mobile users. A more personalised and interesting user experience is the result of data-driven choices, app enhancements, and focused marketing initiatives. Data backup and recovery procedures provide consumers and companies with



security in an unpredictable environment. Maintaining consistent backups of your data reduces the risk of permanent loss in the event of hardware failure or human error. One way to optimise data storage and retrieval is via a process called "data de-duplication." The efficiency of mobile devices and networks may be increased and storage costs decreased by the elimination of redundant information. Data governance is crucial to mobile data management because it establishes standards for ethical data handling, privacy compliance, and legal compliance. Trust between users and mobile service providers may be cultivated by following the guidelines established by this framework for responsible and moral data management. Although the mobile environment is always changing, mobile data management will always be crucial to delivering a smooth, protected, and personalised mobile experience. These high-level ideas are the foundation of this vital field, which is responsible for fostering creativity and efficiency in the mobile ecosystem.

Mobile Data Optimization Techniques

Techniques for optimising mobile data utilisation are crucial for providing a consistent and satisfying experience on smartphones and other mobile devices. Optimizing data consumption has become critical in today's data-intensive environment, when mobile networks often have limited capacity and data plans come with use limits. In the following paragraphs, we will discuss many methods for maximising the efficiency of mobile data:

Compressing data before it is sent over a network or kept on a device is a basic data management practise. Data transport size may be reduced by the use of compression technologies like lossless and lossy compression. This improves data transfer speeds, reduces overall data consumption, and saves money for subscribers on metered plans.

Strategies for enhancing the responsiveness of mobile apps include caching and prefetching. By caching frequently visited data locally on the mobile device, the number of times the same data must be fetched from the server is drastically reduced. In contrast, prefetching takes into account the user's past actions to determine what information will be needed in the future and then downloads it in advance of the user's request. These methods improve the user experience by decreasing the perceived latency, particularly in locations with limited network access.

Data delivery that takes into account the user's current location, time of day, and historical habits is called context-aware data delivery. Mobile applications may optimise the data delivered and the user's engagement by tailoring what they show them based on their specific situation.

Optimization of Images and Other Media Files Large media files, such as photos and movies, may quickly rack up a mobile device's data plan. By optimising these media files, which may be done by lowering their resolution or using cutting-edge compression methods, data utilisation can be decreased without substantially diminishing visual quality.

Data de-duplication is the process of removing duplicate information from a dataset before it is stored locally or sent across a network. This optimization method lessens the burden on mobile networks and saves capacity on end-user devices, ultimately leading to better data administration.



Table 1. Summary of Query Optimization Techniques in Relational Databases: Problems/Solutions/Practices/Techniques

Research Topic	Author(s)	Problem and Solution	Discussed Proposed	Strengths	Limitation/Scope
Query Optimization	Ioannidis [1]	Described the structure of the optimizer and explained the main issues handle by each optimizer module.		Understanding of optimization concepts and main modules of query optimizer.	Dynamic, parallel and distributed optimizations are not discussed.
Query Optimization	Li <i>et al.</i> [2]	Discussed intra-query redundancy in sub-queries. Suggest un-nesting and some other heuristics strategies like selection, projection and joining.		Optimizing query by removing intra-query redundancy.	The experiments performed are not related to the techniques mentioned in the paper.
Genetic optimization for join ordering problem	Sun <i>et al.</i> [3]	Proposed genetic algorithm to face the problem of efficient selection of join ordering for making an optimal plan by an optimizer.		Better execution time for the query by proper join ordering.	In terms of cost, the proposed algorithm is little expensive for more than 20 joins.

Source: Relational database query optimization: a summary of issues, approaches, and best practises <https://d3i71xaburhd42.cloudfront.net/acc05090a4e3f9d177680c2aa50ae5dbd591b8f77-Table1-1.png>

Multimedia content distribution on mobile devices often makes use of adaptive streaming. It automatically optimises the video and audio stream quality for the current connection speed and device capabilities. This method reduces wasteful data transfers by providing the highest attainable quality without taxing the network or triggering buffering problems.

One way to optimise mobile data use is via a process known as "prioritisation and throttling," which involves giving higher priority to some services and data over others. Mobile networks may more effectively deploy resources and guarantee smooth data delivery for crucial operations by recognising critical data and limiting less important applications.

Real-time Data Synchronization

To guarantee a constant and accurate flow of information between mobile devices and backend servers or cloud-based services, real-time data synchronisation is an essential component of mobile data management. Users in today's fast-paced, always-connected mobile technology landscape need instantaneous data access on any device. Maintaining data integrity throughout the whole ecosystem is a top priority, and real-time synchronisation guarantees that any changes made to data on one device are instantly communicated to all linked devices and servers. Through real-time synchronisation, changes made on a user's mobile device, such adding a new contact or updating a document, are instantly synced to the cloud or server. Since a result, users may transition between devices without losing any data, as the most up-to-date version will always be available. In addition, real-time synchronisation is essential in collaborative work settings since it enables several users to work together on the same document in real time, with all changes being immediately visible to all participants. Strong algorithms, efficient network protocols, and trustworthy data storage techniques are the backbone of the technology that enables real-time data synchronisation. Client-side updates are monitored and sent to the server in real time, and the server then immediately updates all other connected clients.

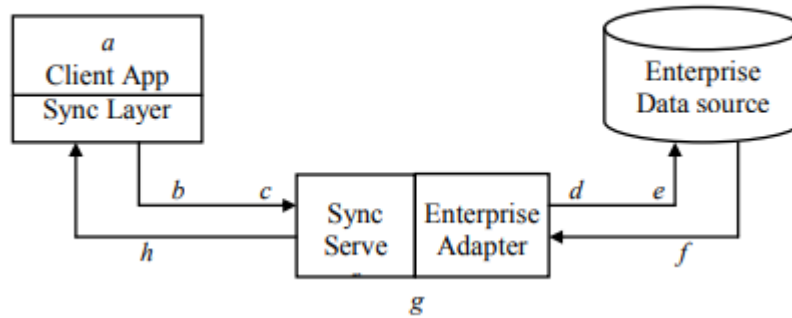

The data synchronization-processing model

This is accomplished using event-based triggers used in real-time synchronisation systems, which ensure that data changes are sent efficiently only when needed. Applications that deal with mission-critical data, including messaging apps, real-time collaboration tools, and financial platforms, especially benefit from real-time data synchronisation. For example, in a messaging app, when a user types a message, it must immediately be sent to the intended recipient and shown on their device. Similarly, in financial systems, real-time synchronisation guarantees that customers always have access to the most up-to-date information on their accounts and transactions. There are difficulties associated with real-time data synchronisation, particularly with regard to data inconsistencies. Conflicts and inconsistencies may occur when many users attempt to update the same data at the same time. In order to elegantly deal with such situations, guaranteeing data integrity while reducing effect on users, conflict resolution techniques must be included. One of the most important aspects of mobile data management is the ability to synchronise data in real time between mobile devices and servers. This synchronisation solution improves the user experience and bolsters the adaptability of the mobile ecosystem by giving users access to the most recent information and allowing for real-time cooperation.

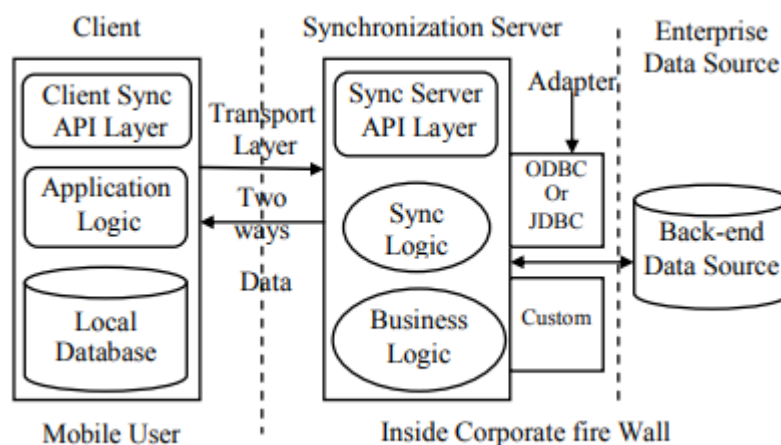

Source: The architecture of data synchronization

Xue, Y. (2008). The Research on Data Synchronization of Distributed Real-Time Mobile Network. 2008 International Conference on Computer Science and Software Engineering. doi:10.1109/csse.2008.1296

Leveraging Caching for Faster Mobile Apps

The usage of caching is an effective method for improving the speed and responsiveness of mobile apps. Network conditions and available bandwidth on the go might be unpredictable. Caching saves



frequently requested data locally, avoiding several network requests for the same information from the server. This reduces the need for network connectivity, which speeds up app response times and lessens waiting periods. A mobile app's cache stores information such as photos, user profiles, and frequently visited material that users have generated via their interactions with the app. Once the information is stored in a cache, subsequent requests may be satisfied without sending any data over the network at all. This means that even in locations with spotty service, customers will enjoy improved load speeds and responsiveness. Caching is particularly helpful for applications that have a lot of material, such as social networking sites, news apps, and video streaming services. Users may quickly access material, such as images, articles, and videos, even while they are offline or in places with poor network coverage provided they have already loaded the information into the cache.

Developers need to find a happy medium between caching frequently visited data to boost speed and avoiding excessive cache utilisation, which might lead to higher storage consumption, in order to reap the full advantages of caching. Strategies for managing caches, such as expiry rules and intelligent data eviction algorithms, keep caches effective and up-to-date. Although caching greatly improves app speed, cache invalidation procedures are still important for situations when data on the server has changed. By forcing the app to update its cache to match the most recent data on the server, cache invalidation eliminates the possibility of users seeing stale or inaccurate data. Caching has many benefits, but it also has its drawbacks, the most significant of which are issues with data consistency. It becomes vital to ensure data integrity when data is modified and the cached data does not reflect these changes. To prevent inconsistencies, developers need to implement cache update algorithms and effectively manage cache refresh. One of the cornerstones of mobile data management is the use of caching to speed up mobile applications. Caching improves app speed by minimising the need for network connections by storing data that is often requested locally on the device. Caching is a crucial tool for app developers in today's data-driven environment, allowing for faster load times, smoother interactions, and better user experiences.

Research Methodology

Research methodology provides a systematic framework for doing research and producing trustworthy and credible results. It shows researchers how to answer questions or test hypotheses. Research methodology is the systematic process used to gather, analyse, and interpret data. Research technique begins with issue definition. This requires explicitly stating the research questions or hypotheses and study scope and constraints. To understand the issue and identify research gaps, researchers must evaluate relevant literature and studies. Then, researchers choose a study strategy and data gathering techniques. Depending on study aims and resources, research designs might be experimental, quasi-experimental, correlational, descriptive, or exploratory. Surveys, interviews, observations, experiments, and secondary data analysis may gather data. After planning, researchers gather data. This phase collects important data from specified people or sources. Ethical research requires informed permission and secrecy. Researchers analyse data to get relevant findings. Statistical or qualitative analysis methods may be employed to draw conclusions and find patterns in the data, depending on the study strategy and data type. Researchers then analyse and make conclusions. Consider the research's ramifications and how they fit into current ideas or advance the field. Researchers present or write on their results. This allows other researchers and professionals to debate and progress the area. Researchers should consider biases, constraints, and study validity throughout the process. A well-structured research technique and meticulous attention to detail improve study credibility and generalizability. Research technique



directs researchers' investigations. Researchers may get new insights and advance their disciplines by identifying study goals, choosing suitable designs and data gathering techniques, and rigorously analysing data.

conclusion

Mobile data management is essential for a smooth mobile experience. Real-time data synchronisation, caching, and data compression may increase mobile app speed, data usage, and responsiveness. Context-aware data transmission allows customised services, increasing user happiness. Mobile data management improves user experience and data security and privacy. Encryption, access restrictions, and data anonymization protect critical user data, boosting mobile service trust. Mobile data management data analytics helps organisations understand user behaviour and market trends, enabling data-driven app upgrades. Data governance principles help mobile apps comply with rules and industry standards, preserving user data and reducing data risks. Mobile data management optimises data transit, storage, and consumption for consumers and service providers. Data de-duplication saves storage space, while prioritisation and throttling optimise network resources for better user experiences during peak hours. Mobile data management's emphasis on offline data access ensures that customers may utilise important app functions even without internet connection. This makes mobile apps more accessible and usable for many user circumstances. Mobile data management has several goals and approaches. Mobile data management creates a dynamic and seamless mobile environment for consumers and service providers by aligning data management methods with user preferences, network circumstances, and business needs. This field's ongoing research and innovation will influence mobile technology's future and improve everyone's mobile experience.

References

1. Kim, Y., Choi, K. (2016). Mobile cloud computing architecture, applications, and methods. 40, 14-30.
2. Zhang, Wen, Li, B., and He, Y. (2015). Mobile cloud computing survey. 15(12), 1717-1735.
3. Alqahtani, S., Alhowaish, M., Aldossary, M., Almohri, Y., & Alshahrani (2018). Mobile edge computing architectures, applications, and research issues. *IEEE Access*, 6(79529)–79554.
4. Rani, S., Choudhary, A., Mishra, N. (2019). Mobile data management methods and issues. *International Conference on Intelligent Computing and Control Systems (ICCS) 2019*. (pp. 197-202). IEEE.
5. Malipatil, M.M., & Ghatol, A.A. (2018). Mobile big data management study. 100, 1-18.
6. Chen, L.; Wang, J.; Zheng, K. (2017). Mobile big data architecture, administration, and security. 22(1), 6-18.
7. C. Miao, Y. Qian, Z. Ma, H. Wang, & J. Cao (2018). Mobile data gathering in wireless sensor networks: Problems, solutions, and prospects. 20(4), 2875–2902.
8. Singh and Kaur, M. (2019). Mobile data offloading: A detailed study. 128, 1-21.
9. Wu, Z., Yang, C., Wang, J., & Lui, J.C. (2020). Mobile edge caching difficulties, challenges, and potential. *IEEE Communications Surveys & Tutorials*, 22(1), 556-592.
10. Wu, D., Zhang, X., and Liu, W. (2019). Mobile data pricing: cellular networks to large data. *IEEE Communications Surveys & Tutorials* 21(1):507-534.
11. & Borcea, C. (2019). Mobile cloud computing architecture, applications, and methods. 52(5), 1-37.
12. Saberali, R., Jahanshahi, M.R., & Atani, R.E. (2017). IoT mobile data management survey. *IJIM* 37(3), 183-194.



13. *source* : Mobile device management
https://cdn.ttgtmedia.com/rms/onlineImages/mobile_computing-mdm_mobile.jpg
14. Source: Summary of Query Optimization Techniques in Relational Databases: Problems/Solutions/Practices/Techniques,<https://d3i71xaburhd42.cloudfront.net/acc05090a4e3f9d177680c2aa50ae5dbd591b8f77-Table1-1.png>
15. Source: The architecture of data synchronization
16. Xue, Y. (2008). The Research on Data Synchronization of Distributed Real-Time Mobile Network. 2008 International Conference on Computer Science and Software Engineering. doi:10.1109/csse.2008.1296