



## A Review of Biasing Conditions for Standard Junction Diode and its Characteristics

<sup>1</sup>Atul Kumar Gupta , <sup>2</sup>K. K. Tiwari

Department of Physics, Allahabad Degree College  
University of Allahabad, India , email : atulkumar\_physics@rediffmail.com

**Abstract :** A *PN Junction Diode* is one of the simplest semiconductor devices around, and which has the characteristic of passing current in only one direction only. However, unlike a resistor, a diode does not behave linearly with respect to the applied voltage as the diode has an exponential current-voltage ( I-V ) relationship and therefore we can not described its operation by simply using an equation such as Ohm's law.

ISSN 2454-308X



If a suitable positive voltage (forward bias) is applied between the two ends of the PN junction, it can supply free electrons and holes with the extra energy they require to cross the junction as the width of the depletion layer around the PN junction is decreased.

By applying a negative voltage (reverse bias) results in the free charges being pulled away from the junction resulting in the depletion layer width being increased. This has the effect of increasing or decreasing the effective resistance of the junction itself allowing or blocking current flow through the diode.

Then the depletion layer widens with an increase in the application of a reverse voltage and narrows with an increase in the application of a forward voltage. This is due to the differences in the electrical properties on the two sides of the PN junction resulting in physical changes taking place.

**Key Words :** *PN Junction Diode* , Zero Bias , Reverse Bias , Forward Bias

## Junction Diode Symbol and Static I-V Characteristics

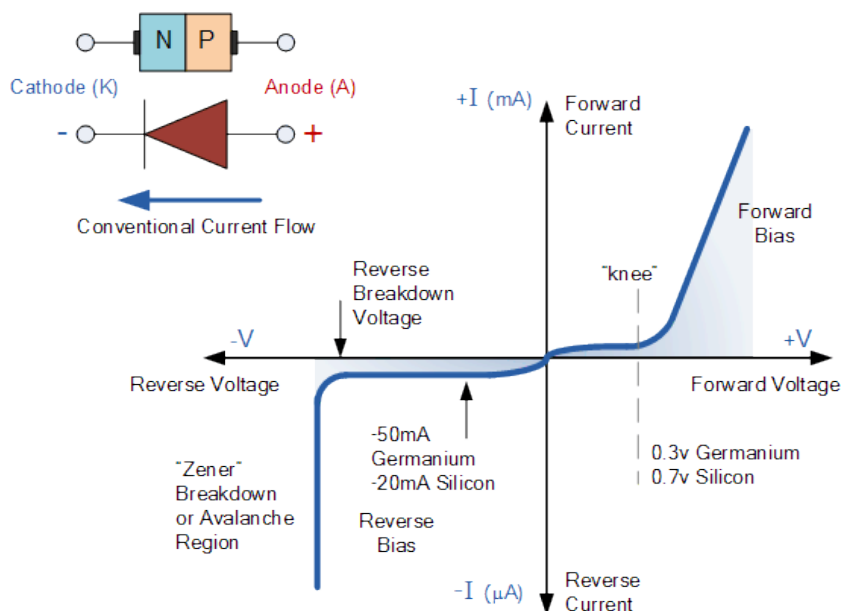

But before we can use the PN junction as a practical device or as a rectifying device we need to firstly **bias** the junction, ie connect a voltage potential across it. On the voltage axis above, “Reverse Bias” refers to an external voltage potential which increases the potential barrier. An external voltage which decreases the potential barrier is said to act in the “Forward Bias” direction.

There are two operating regions and three possible “biasing” conditions for the standard **Junction Diode** and these are:

- 1. Zero Bias – No external voltage potential is applied to the PN junction diode.
- 2. Reverse Bias – The voltage potential is connected negative, (-ve) to the P-type material and positive, (+ve) to the N-type material across the diode which has the effect of **Increasing** the PN junction diode’s width.
- 3. Forward Bias – The voltage potential is connected positive, (+ve) to the P-type material and negative, (-ve) to the N-type material across the diode which has the effect of **Decreasing** the PN junction diodes width.

### Zero Biased Junction Diode

When a diode is connected in a **Zero Bias** condition, no external potential energy is applied to the PN junction. However if the diodes terminals are shorted together, a few holes (majority carriers) in the P-type material with enough energy to overcome the potential barrier will move across the junction against this barrier potential. This is known as the “**Forward Current**” and is referenced as  $I_F$



Likewise, holes generated in the N-type material (minority carriers), find this situation favorable and move across the junction in the opposite direction. This is known as the “**Reverse Current**” and is referenced as  $I_R$ . This transfer of electrons and holes back and forth across the PN junction is known as diffusion, as shown below.

### Zero Biased PN Junction Diode

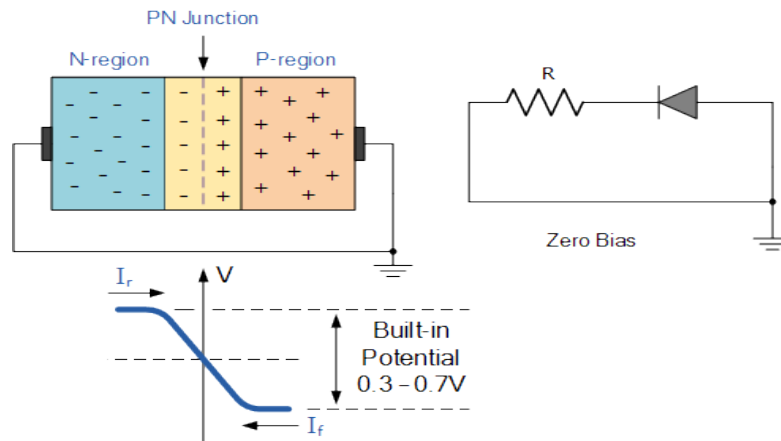

The potential barrier that now exists discourages the diffusion of any more majority carriers across the junction. However, the potential barrier helps minority carriers (few free electrons in the P-region and few holes in the N-region) to drift across the junction.

Then an “Equilibrium” or balance will be established when the majority carriers are equal and both moving in opposite directions, so that the net result is zero current flowing in the circuit. When this occurs the junction is said to be in a state of “**Dynamic Equilibrium**”.

The minority carriers are constantly generated due to thermal energy so this state of equilibrium can be broken by raising the temperature of the PN junction causing an increase in the generation of minority carriers, thereby resulting in an increase in leakage current but an electric current cannot flow since no circuit has been connected to the PN junction.

### Reverse Biased PN Junction Diode

When a diode is connected in a **Reverse Bias** condition, a positive voltage is applied to the N-type material and a negative voltage is applied to the P-type material.

The positive voltage applied to the N-type material attracts electrons towards the positive electrode and away from the junction, while the holes in the P-type end are also attracted away from the junction towards the negative electrode.



The net result is that the depletion layer grows wider due to a lack of electrons and holes and presents a high impedance path, almost an insulator. The result is that a high potential barrier is created thus preventing current from flowing through the semiconductor material.

### Increase in the Depletion Layer due to Reverse Bias

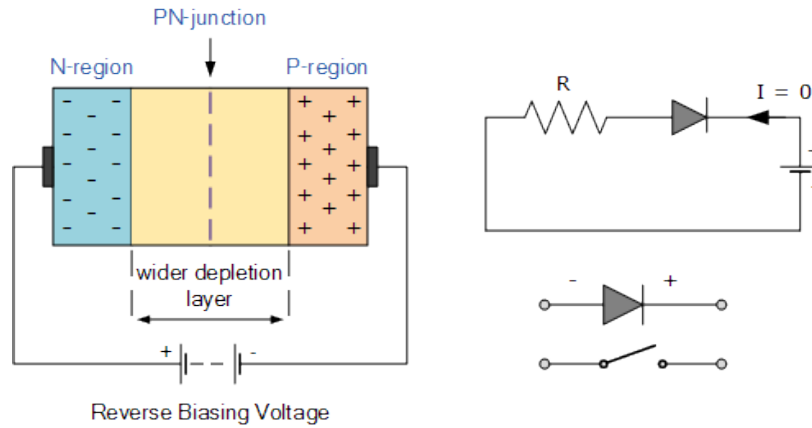

This condition represents a high resistance value to the PN junction and practically zero current flows through the junction diode with an increase in bias voltage. However, a very small **leakage current** does flow through the junction which can be measured in micro-amperes, ( $\mu\text{A}$ ).

One final point, if the reverse bias voltage  $V_r$  applied to the diode is increased to a sufficiently high enough value, it will cause the diode's PN junction to overheat and fail due to the avalanche effect around the junction. This may cause the diode to become shorted and will result in the flow of maximum circuit current, and this shown as a step downward slope in the reverse static characteristics curve below.

### Reverse Characteristics Curve for a Junction Diode

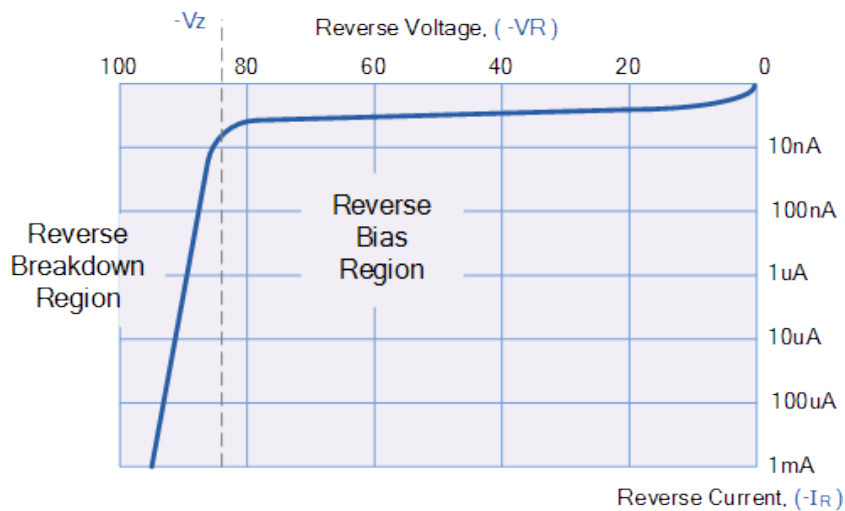



Sometimes this avalanche effect has practical applications in voltage stabilising circuits where a series limiting resistor is used with the diode to limit this reverse breakdown current to a preset maximum value thereby producing a fixed voltage output across the diode. These types of diodes are commonly known as Zener Diodes and are discussed in a later tutorial.

### Forward Biased PN Junction Diode

When a diode is connected in a **Forward Bias** condition, a negative voltage is applied to the N-type material and a positive voltage is applied to the P-type material. If this external voltage becomes greater than the value of the potential barrier, approx. 0.7 volts for silicon and 0.3 volts for germanium, the potential barriers opposition will be overcome and current will start to flow. This is because the negative voltage pushes or repels electrons towards the junction giving them the energy to cross over and combine with the holes being pushed in the opposite direction towards the junction by the positive voltage. This results in a characteristics curve of zero current flowing up to this voltage point, called the “knee” on the static curves and then a high current flow through the diode with little increase in the external voltage as shown below.

### Forward Characteristics Curve for a Junction Diode

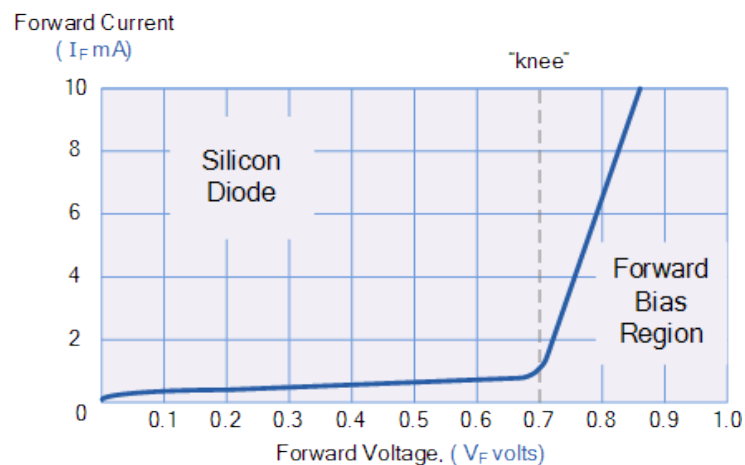

The application of a forward biasing voltage on the junction diode results in the depletion layer becoming very thin and narrow which represents a low impedance path through the junction thereby allowing high currents to flow. The point at which this sudden increase in current takes place is represented on the static I-V characteristics curve above as the “knee” point.

### Reduction in the Depletion Layer due to Forward Bias

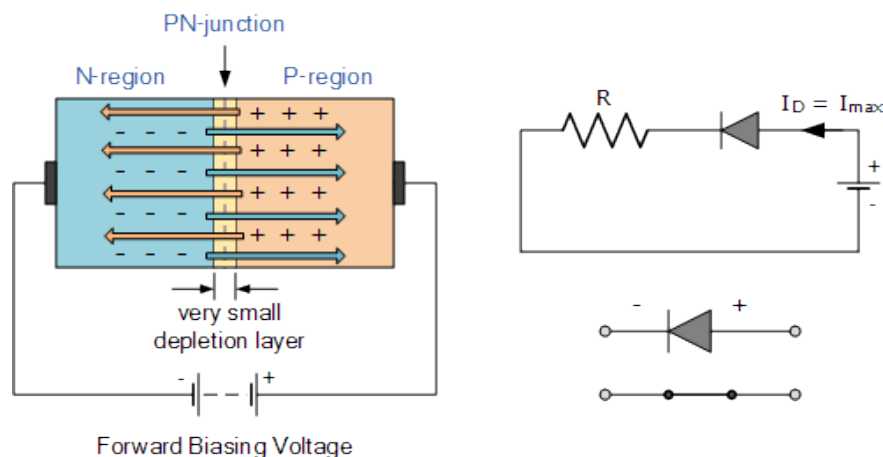

This condition represents the low resistance path through the PN junction allowing very large currents to flow through the diode with only a small increase in bias voltage. The actual potential difference across the junction or diode is kept constant by the action of the depletion layer at approximately 0.3v for germanium and approximately 0.7v for silicon junction diodes.

Since the diode can conduct “infinite” current above this knee point as it effectively becomes a short circuit, therefore resistors are used in series with the diode to limit its current flow. Exceeding its maximum forward current specification causes the device to dissipate more power in the form of heat than it was designed for resulting in a very quick failure of the device.

### References :

- [1] Solid State Electronic Devices, Fifth edition, B. G. Streetman, Prentice Hall, 2000.
- [2] Electrons and holes in semiconductors, W. Shockley, D. Van Nostrand Company, 1959.
- [3] Physics of Semiconductor Devices, Second edition, S. M. Sze, Wiley & Sons, 1981.
- [4] Device Electronics for Integrated Circuits, Second edition, R.S. Muller and T. I. Kamins, Wiley & Sons, 1986.